

(No Model.)

2 Sheets—Sheet 1.

J. HUNTER.

WATCH MAKER'S LATHE.

No. 354,601.

Patented Dec. 21, 1886.

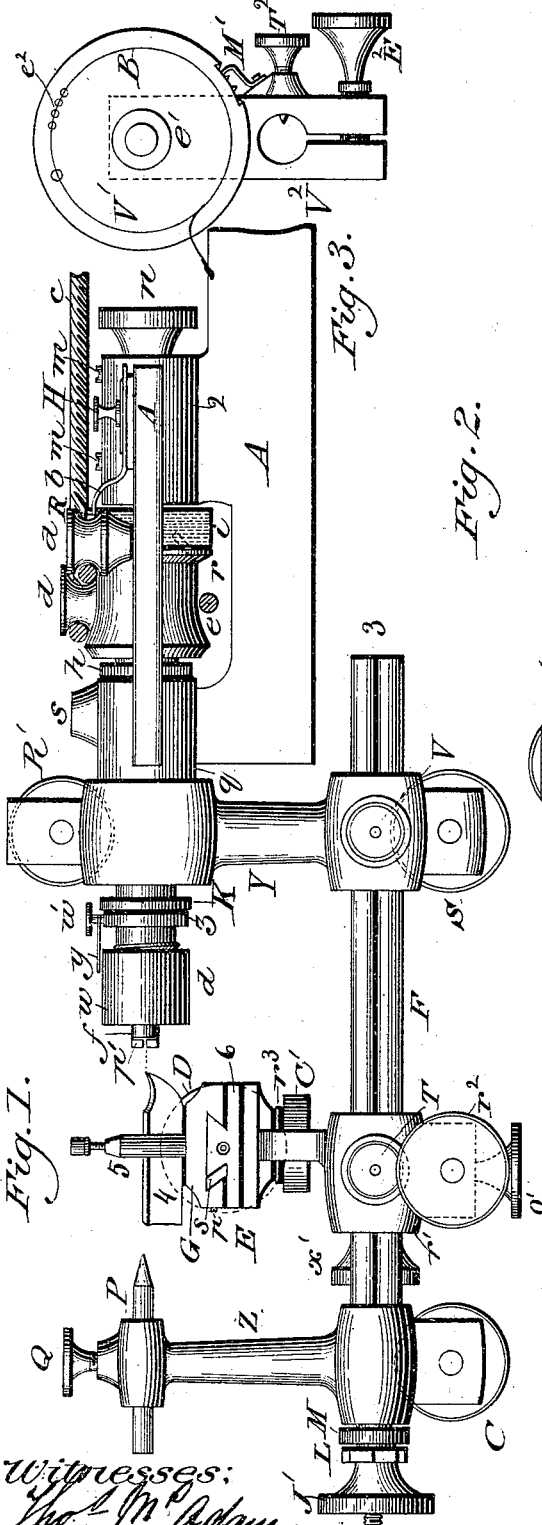

Fig. 1.

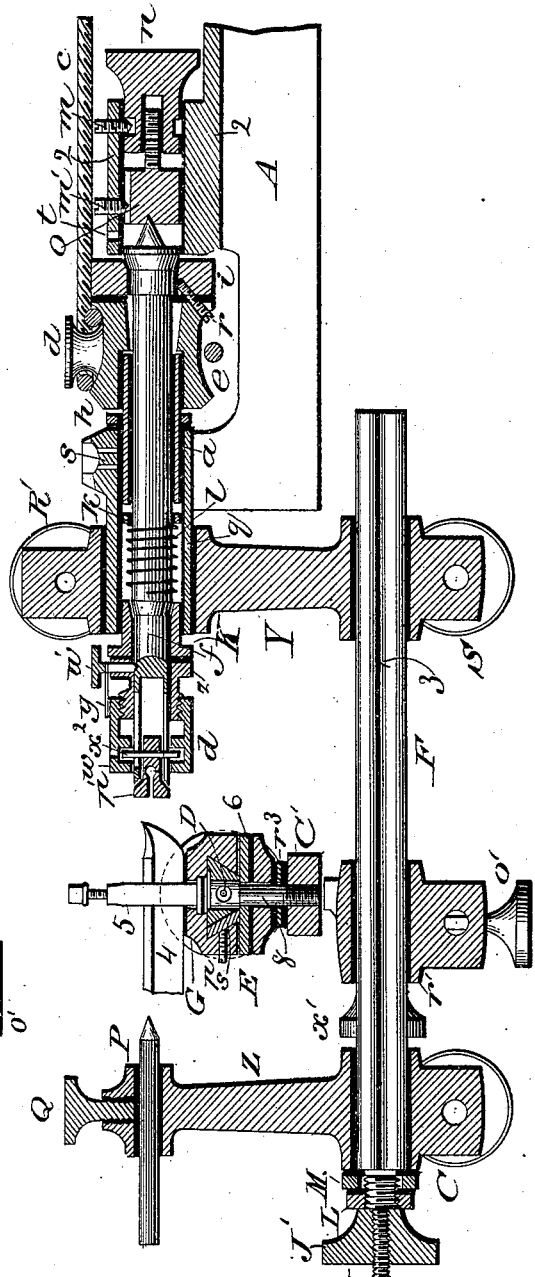

Fig. 2.

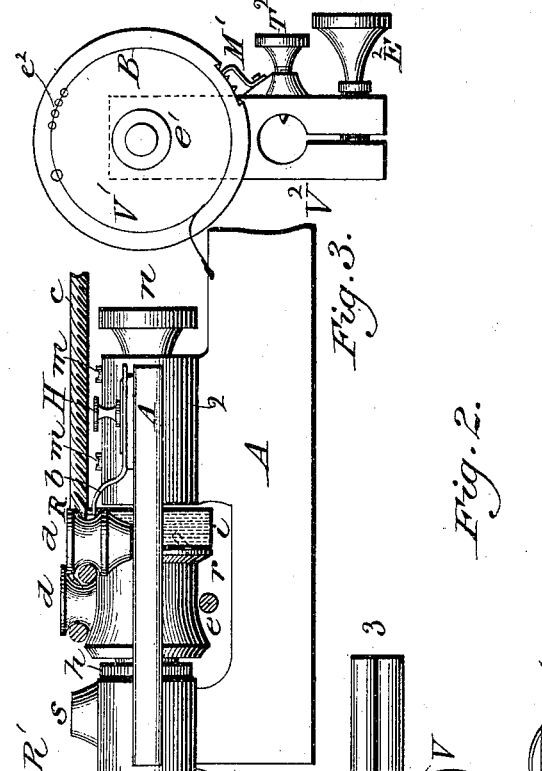

Fig. 3.

Witnesses:
 Geo. M. Adams
 John. Mc Mahon

Inventor:
 John Hunter

J. HUNTER.

WATCH MAKER'S LATHE.

No. 354,601.

Patented Dec. 21, 1886.

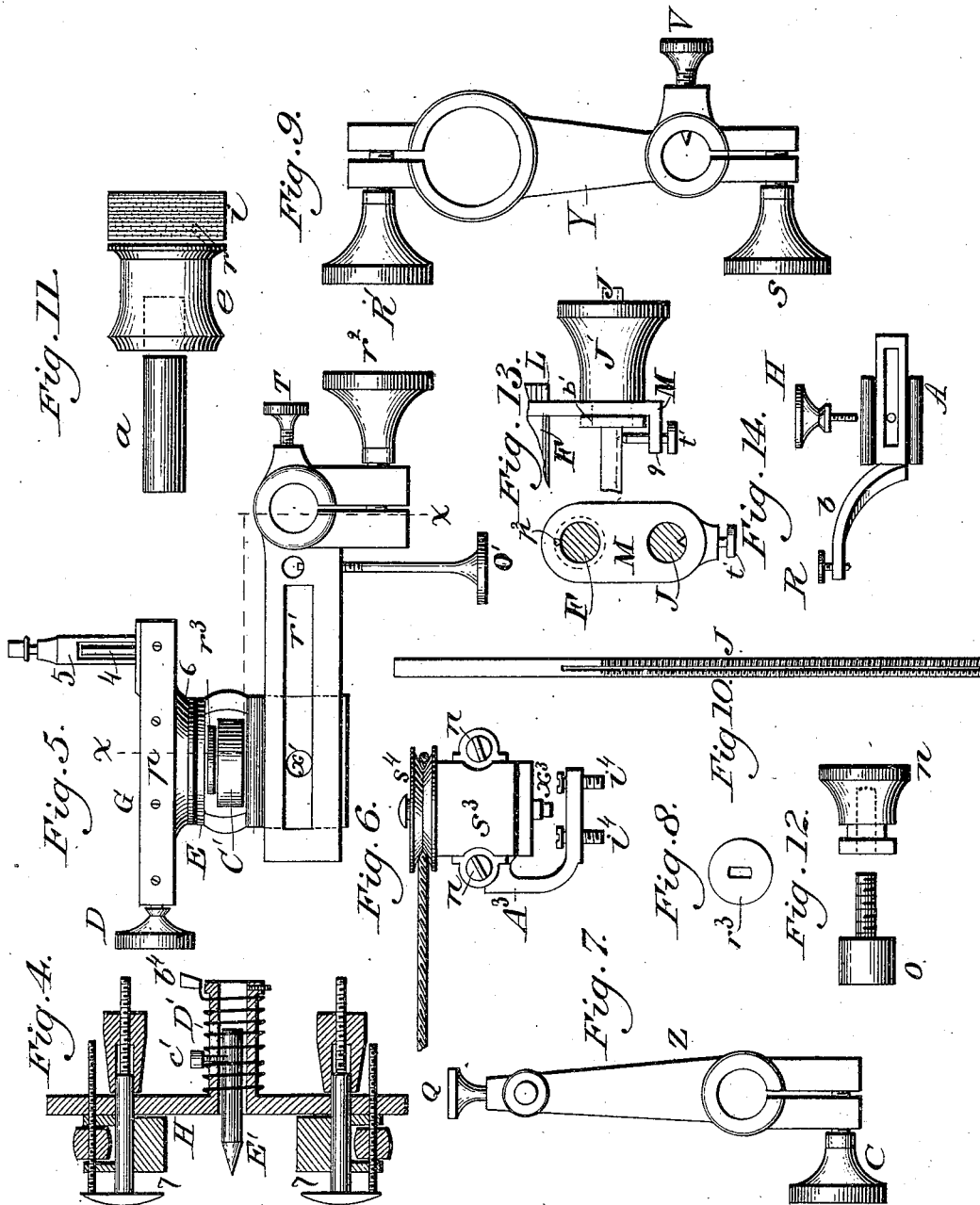

Witnesses:
 Geo. M. Adams
 John S. McMahon

Inventor:
 John Hunter

UNITED STATES PATENT OFFICE.

JOHN HUNTER, OF KINGSTON, ONTARIO, CANADA.

WATCH-MAKER'S LATHE.

SPECIFICATION forming part of Letters Patent No. 354,601, dated December 21, 1886.

Application filed May 1, 1886. Serial No. 200,859. (No model.) Patented in Canada July 9, 1885, No. 22,051.

To all whom it may concern:

Be it known that I, JOHN HUNTER, a citizen of Canada, residing at Kingston, in the county of Frontenac and Province of Ontario, Canada, have invented certain new and useful Improvements in Watch-Makers' Lathes, of which the following is a specification.

This invention relates to that class of lathes which are used for drilling, turning, gear-cutting, &c., and in some particulars it relates to improvements on my drilling apparatus patented September 1, 1885, No. 325,414.

The object of the invention is, first, to adapt the latheways and its attachments to be readily removed from the head-stock; secondly, to provide means for taking up the slack caused by wear and for readily replacing the bearings when worn; thirdly, to provide means for quickly centering and securing work in the spindle, and fourthly, to provide a rest midway the ways for work of various sizes, &c., as will hereinafter appear.

To this end my invention consists in the construction and combination of parts forming a watch-maker's lathe, hereinafter described and claimed, reference being had to the accompanying drawings, in which—

Figure 1 is a rear side elevation of a lathe, showing my invention with the turning-tool carriage in place for service. Fig. 2 is a longitudinal vertical section of the same, partly in elevation, the section of the tool-carriage being on the line *x x*, Fig. 5. Fig. 3 is an end view of a steady-rest and a guide or disk to be secured upon the latheway to aid in doing certain kinds of work. Fig. 4 is a longitudinal section of a face-plate for use upon the lathe-spindle, showing jaws for holding work and a self-adjusting center. Fig. 5 is a right-hand side view of a tool-carriage for the lathe. Fig. 6 is a side elevation of a gear-cutting device adapted to be fastened upon the tool-carriage shown in Fig. 5. Fig. 7 is an elevation of the center holding-clamp or the tail-stock of the lathe. Fig. 8 shows a washer with an oblong hole. Fig. 9 is an elevation of a clamp to connect the latheway with the head-stock. Fig. 10 represents the feed-screw grooved. Fig. 11 represents in side elevation the sleeve, driving-pulley, and index cylinder for spacing gear-teeth. Fig. 12 represents a tension-screw and thumb-nut. Fig. 13 represents the bracket

for supporting the feed-screw and a binding screw-nut. Fig. 14 represents an adjustable pointer for the index.

A represents the head-stock, adapted to be held in a vise, or by any suitable support, and provided with bearings *q 2* for the spindle *f*.

a is a sleeve journaled to revolve upon the spindle *f* within the bearing *q*, and provided with a collar, *h*, to bear against the end of bearing *q*.

e is a pulley firmly secured upon the sleeve *a*, to be revolved by a band, *c*, which receives its motion from any suitable drive-wheel, and is directed upon the pulley *e* by pulleys *d*.

i is a cylinder firmly fixed upon the spindle *f*, and perforated in its circumference with circles of holes to serve as an index for spacing gear-teeth in wheels held centrally in the working end of the spindle *f*.

b is a pointer carrying a screw, *R*, Fig. 14, and fitted to slide in the head-stock *A*, and provided with a binding-screw, *H*, whereby the pointer may be set to engage its pointing-screw *R* with the holes of any circle of the index.

O is the spindle-step, fitted to slide in the bearing 2.

n is a thumb-nut circumferentially grooved to engage a screw, *m*, and threaded to receive a screw projecting from the step *O*. By turning the thumb-nut *n* the step may be moved forward or backward. The step *O* is longitudinally grooved to be held by a screw, *m'*, from being turned by the action of the nut *n*. The pulley *e*, being supported in the bearing *q* by the sleeve *a*, may revolve continually without revolving the spindle *f*. By pressing the step *O* forward with the nut *n* the spindle *f* is moved forward and the cylinder *i* thereon is brought into frictional contact with the pulley *e*, whereby the spindle will be revolved with sufficient force for light work.

r is a screw, which may be placed through the rim of the pulley *e* into the cylinder *i*, to connect the two positively for heavy work.

s represents oil-holes in the bearing *f* to oil the sleeve *a*, and *t* an oil-hole in bearing 2 to admit oil to the step *O*.

K is a sleeve-bearing for the forward end of the spindle *f*, fitted to be driven closely into the bearing *q*, and made internally conical at its inner or rear end to fit a conical shoulder on the spindle *f*. This shoulder-fit should

take place when the cylinder *i* bears against the pulley *e* to bring the spindle in perfect central line.

k is a collar fixed upon the spindle, and *l* is a spring, acting between the bearing K and collar *k*, to force the spindle into its step, thereby centering its rear end and disengaging the cylinder *i* from the pulley *e* when the nut *n* is turned back. The latheway F is a single bar provided with a slot, 3, in one side of it. It is connected with the head-stock A by means of a clamp, Y, Figs. 1 and 9, which is split to the holes and provided with a binding-screw, R, whereby it may be firmly fixed while standing at any angle around a cylindrical extension of the bearing *q* of the head-stock A, the said cylindrical extension being concentric with the spindle and with a screw, S, for binding the clamp Y upon the way F.

V is a set-screw to enter the groove 3, to keep the way from revolving.

Z is the tail-stock, also split at its lower end, and provided with a binding-screw, C, to fasten it upon the way F.

P is the dead-center, and Q is a binding-screw therefor.

r' represents the tool-carriage, fitted to slide longitudinally upon the way F, and provided with a pointed screw, T, to engage the groove 3 to keep the carriage from turning around the way F. The carriage is split through its bottom, and provided with a binding-screw, *r''*, whereby it may be clamped with any degree of firmness upon the way F.

4 is a tool.

5 is a tool-post set in the tool-block G, which is gibbed to slide upon a base-piece, 6, and provided with binding-screws *p*.

E is a bridge-piece connecting the base 6 with the carriage *r'*, and fitted to slide transversely to the way upon the said carriage and provided with a thumb-screw, *x'*, fitted to enter a groove in the carriage to bind the bridge thereon at any required point.

8 is a pivot-bolt for binding the base 6 upon the bridge E, by means of the nut C', accessible through the bridge.

r'' is a washer placed between the nut C' and the bridge to prevent the nut being unscrewed by turning the tool-block upon the bridge. The lower portion of the base 6 is circular and graduated to degrees, &c., so that the tool-block may be set at any required angle with the axis of the work.

D is a feed-screw for traversing the tool-block G on its base 6, and the head of the bolt 8 is the nut for this screw, so that the action of the tool-block will be the same when set at any angle.

J is the feed-screw for the carriage, which may be secured to it at any point by the set-screw O'.

M is a bracket fitted upon a stud on the end of the way F, and secured by a screw-nut, L, and a stud-pin from the way entering the hole *p''* in the bracket. A thumb-nut, J', upon the screw J has a bearing in the bracket M,

and is retained in the bearing by a fixed collar, *b'*. By turning the nut J' the screw J is bodily moved, and the carriage *r'* is fed either way.

9 is an offset of the bracket M, carrying a screw, *t'*, to enter the groove in the screw J, to prevent the lathe, which is very light, from being twisted by turning the nut J'. To form a chuck for holding work, the end of the spindle *f* is bored to receive the body of the spring-jaws *p'*, and conically counterbored to fit the conical shoulder of the said jaws.

x'' is a pin passing through the body of the jaws *p'*, and projecting through slots in the spindle *f* and into an annular groove within a nut, *w*. *z* is a sleeve driven firmly onto the spindle *f*, and secured thereon by a screw, *w'*. The nut *w* is screw-threaded upon the sleeve *z*, and on being rotated it acts on the pin *x''* to move the jaws *p'* into or out of the tapered end of the spindle, thereby closing or opening the jaws to hold or release work.

y is a finger secured upon the nut *w*, and projecting therefrom into the path of the screw *w'* to prevent the nut from being accidentally turned off from the sleeve. When the finger *y* rests against the screw *w'*, holes through the nut *w* are in line with the pin *x''*, so that the latter may be placed or removed through the holes. The steady-rest, Fig. 3, consists of a disk, V', journaled on a stud, *e'*, which is fixed in a clamp, V², adapted to be secured upon the way F by means of the clamp-screw E² and a set-screw, T², arranged to fit the groove 3. The circle B on the disk V' comes into the line of lathe-centers, and the disk is perforated with holes *e''* of various sizes and forms, in which to rest work.

M' is a spring-detent fitted to engage notches or teeth in the circumference of the disk V', to hold the same steady at any point where a hole, *e''*, is in the line of centers.

H is a face-plate for holding work adapted to be secured on the lathe-spindle *f* when the sleeve *z* is removed. The face-plate is provided with jaws 7 for holding work.

E' is a center provided with a screw, *c'*, extending through a slot in the hub of the face-plate to be engaged by a spiral spring, D', which is provided with a handle, *b''*, whereby it may be revolved to screw the center E' out or in, and to whatever point the center is thus adjusted it will be returned by the spring if the said center be pressed out or in, thus automatically returning to the working-point.

The gear-cutting device, Fig. 6, consists of a cutter-arbor, *x''*, journaled in a box, *s''*, and provided with a band-pulley, *s'*. The box has a bracket, A³, and screws *i''*, by which it is mounted and secured on the tool-block G when the tool-post 5 is removed. The gear to be cut is to be held in the jaws *r'* of the spindle *f*, the belt *c* is taken off, the screw *r* is put in place, as in Fig. 2, the index-pointer *b* is to be set to register with the required circle of holes on the graduated cylinder *i*, and then, by means of the screws D and J, the cutter

may be moved as required to cut the teeth, one at a time, as usual. Thus, by means of the various appliances hereinbefore described, this lathe is adapted to do all kinds of watch-makers' lathe-work.

What I claim as my invention, and desire to secure by Letters Patent, is—

1. The combination, in a lathe, of the head-stock A, provided with the bearing *g*, the sleeve *a*, fitted to revolve in the said bearing and provided with the collar *h*, the pulley fitted tightly upon the sleeve *a*, and the spindle *f*, passing freely through the said pulley and journaled to revolve in the said sleeve, substantially as shown and described.

2. The combination of the head-stock A, provided with the bearing *g*, the sleeve *a*, journaled therein, the pulley *e*, tightly fixed on the said sleeve, the spindle *f*, passing freely through the said pulley and journaled in the sleeve, the graduated cylinder *i*, fixed upon the spindle, and the screw *r*, fitted to connect the said cylinder and pulley.

3. The combination of the head-stock A, provided with spindle-bearings, the slotted spindle-step O, having a screw projecting from its rear end and fitted into one of the said spindle-bearings, the circumferentially-grooved thumb-nut *n*, fitted into the said bearing and engaging the said projecting screw, the screw *m'*, fitted to engage the groove in the said step, and the screw *m*, fitted to engage the groove in the said thumb-nut.

4. The combination of the head-stock A, having bearings *g* and 2, the sleeve K, fitting tightly in bearing *g* and bored cylindrically through its body and bored conically at its rear end, the spindle *f*, having a cylindrical portion to fit easily in the said cylindrical bore, and a conical shoulder to fit the conical portion of the said bore, and a step for the rear end of the spindle.

5. The combination of the head-stock A, having bearings *g* and 2, the sleeve K, conically bored, the spindle *f*, having a conical shoulder fitted to the said conical bore, the screw-step O, and the screw-nut *n*, fitted in the bearing 2, and the screws *m* and *m'*.

6. The spindle *f*, the cylinder *i*, fixed thereon and perforated with holes in circles in its circumference, the pointer *b*, fitted to slide in the head-stock A, the binding-screw H, and the index-screw R.

7. The combination of the head-stock A, provided with the bearing *g*, having a circumferentially-cylindrical extension, the bracket Y, fitted upon the said extension and provided with the clamp and screw R', and the way F, fitted into the clamp Y.

8. The combination of the clamp Y, perforated and split at its lower end, the binding-screw S, the pointed set-screw V, the cylindrical way F, fitting the said perforation and provided with a longitudinal groove, 3, the

tail-stock Z, fitted upon the way F and split at its lower end, and the binding-screw C.

9. The combination of the grooved cylindrical latheway F, the carriage *r'*, fitted upon the said way and split in its under side, the clamping-screw *r''*, and the set-screw T, fitted to the groove in the way.

10. The combination of the carriage *r'*, the bridge E, fitted thereon, the binding-screw *w'*, the base 6, the pivot-bolt 8, the nut C', accessible through the bridge, the washer *r''*, and the tool-block G, fitted to slide on the base 6.

11. The combination of the bridge E, the base 6, the pivot-bolt 8, connecting the base and bridge, the tool-block G, fitted to slide on the said base, and the feed-screw D, threaded through the pivot-bolt 8.

12. The combination of the horizontally-perforated carriage *r'*, the binding-screw O', entering said perforation transversely thereto, the feed-rod J, fitted to pass freely through the said perforation, the bracket M, and the screw-nut J' upon the rod J, journaled in the bracket M, and provided with a removable collar, *b'*.

13. The grooved feed-rod J, the bracket M, having the offset 9, the screw-nut J', journaled in the bracket M, and provided with the collar *b'*, and the screw *t'* in the offset 9, fitted to engage the groove in the feed-rod J.

14. The combination of the spindle *f*, bored and slotted in its end, the spring-jaws *p'*, having a conical shoulder and a body to fit within the spindle, the pin *x''*, passing through the body of the jaws and projecting through the slot of the spindle, the sleeve *z*, secured upon the spindle *f*, and the nut *w*, screw-threaded upon the said sleeve and internally annularly grooved to receive the ends of the pin *x''*.

15. The combination of the bored and slotted spindle *f*, the jaws *p'*, the pin *x''*, the sleeve *z*, fixed on the spindle, the screw *w'* in the sleeve, the perforated nut *w*, screw-threaded upon the sleeve and engaging the pin *x''*, and the finger *y*, extending from the nut *w* across the path of screw *w'*.

16. The combination of latheway F, the bracket V², fitted thereto, the binding-screw E², the set-screw T², the disk V', perforated with holes in a circle coinciding with the line of centers of the lathe, and provided with notches in its circumference corresponding with the said holes, each, respectively, when in line of centers, and the spring-detent M'.

17. The combination of the face-plate H, having a slotted hub fitted to the spindle of the lathe, the center E', provided with the projecting screw *c'*, and the spiral spring D', provided with the handle *b''*, all substantially as shown and described, for the purpose specified.

JOHN HUNTER.

Witnesses:

THOS. MCADAM,

JNO. A. MCMAHON.